



Clear View

LP Gas Tanks™

The best choice is clear.



 **RAGASCO USA**

Developed by Ragasco AS

- Leading worldwide developer of composite LPG cylinders
- Manufactures Clear View cylinders at high-volume production facility in Raufoss, Norway
- Most advanced production line for composite pressure cylinders
 - Combines the latest blow molding and injection molding machinery with state-of-the-art filament winding technology
- ISO 9001:2000 certified

Manufacturing Process



HDPE liner
blow molded



Fiberglass layer
filament winding
and oven-curing



Test Process:
pneumatic
pressure
and tightness



Three-piece casing
injection molding
with mechanical
joint

Three-Layer Construction



1

Seamless polymer liner contains the gas



2

Fiber structure holds pressure and prevents bursting under extreme conditions



3

Fully integrated outer casing protects valve and pressure vessel and gives Clear View its unique appearance

1. Seamless Polymer Liner



- High Density Poly Ethylene (HDPE)
- Safer one-piece pressure vessel
- Blow molded in-house
- Chemical-resistant
- Gas-tight
- Boss with brass insert welded to liner
- Pressure resistant to 2–3 bar

2. Composite Layer



- Fiberglass with vinylester resin
- Fully automated in-house manufacturing process
- Pressure-resistant
- Chemical-resistant
- UV-resistant

3. Outer Casing



- Three-piece injection molded HDPE with mechanical joint
- Provides protection against impact
- Stackable and easily handled
- Maintains appearance of Clear View cylinder for a lifetime of use

Valve/Cylinder Interface

Injection molded HDPE boss with brass insert

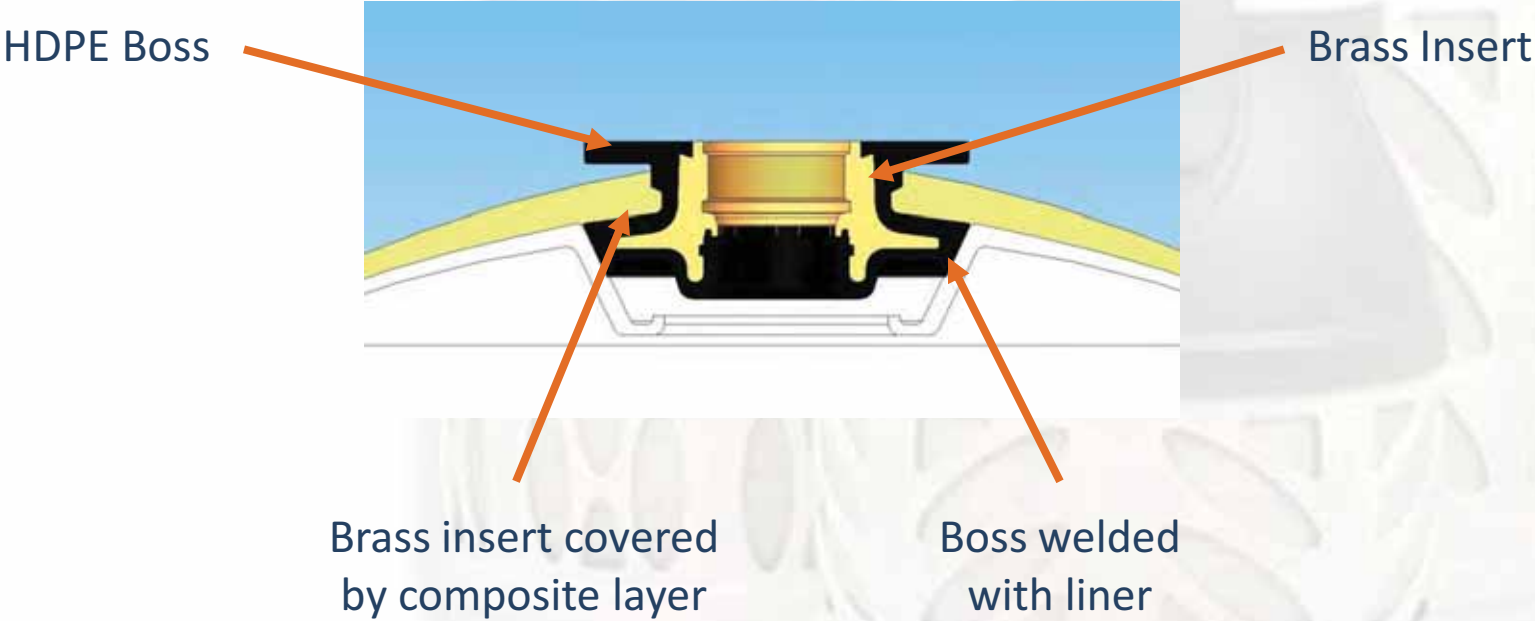

Valve/OPD Standard

D.O.T. Approved Overfill Protection



Fire Resistance Test



Comparative fire test of Clear View vs. steel cylinder

RESULTS:

Clear View:
Controlled LP gas
burn off,
NO EXPLOSION



Steel:
EXPLOSION



Technical Specifications



Propane capacity	11.0 lbs	17.0 lbs	22.0 lbs	31.0 lbs
Butane capacity	13.2 lbs	18.7 lbs	26.0 lbs	37.0 lbs
Water capacity	27.5 lbs	40.4 lbs	53.0 lbs	75.0 lbs
Overall Length (L)	15.24 in	18.1 in	22.5 in	28.3 in
Height to top of boss (H)	11.84 in	14.4 in	19.1 in	24.8 in
Diameter (D)	12.0 in	12.0 in	12.0 in	12.0 in
Tare weight (ex valve)	7.48 lbs	9.0 lbs	11.0 lbs	16.5 lbs

For More Information

Clear View
LP Gas Tanks™

Distributed by Ragasco USA, Inc.

www.RagascoUSA.com

sales@RagascoUSA.com

800-823-6677



 **RAGASCO USA**